

B088, Rev. -

1. Finish Goods PKG photo



2. Packing method

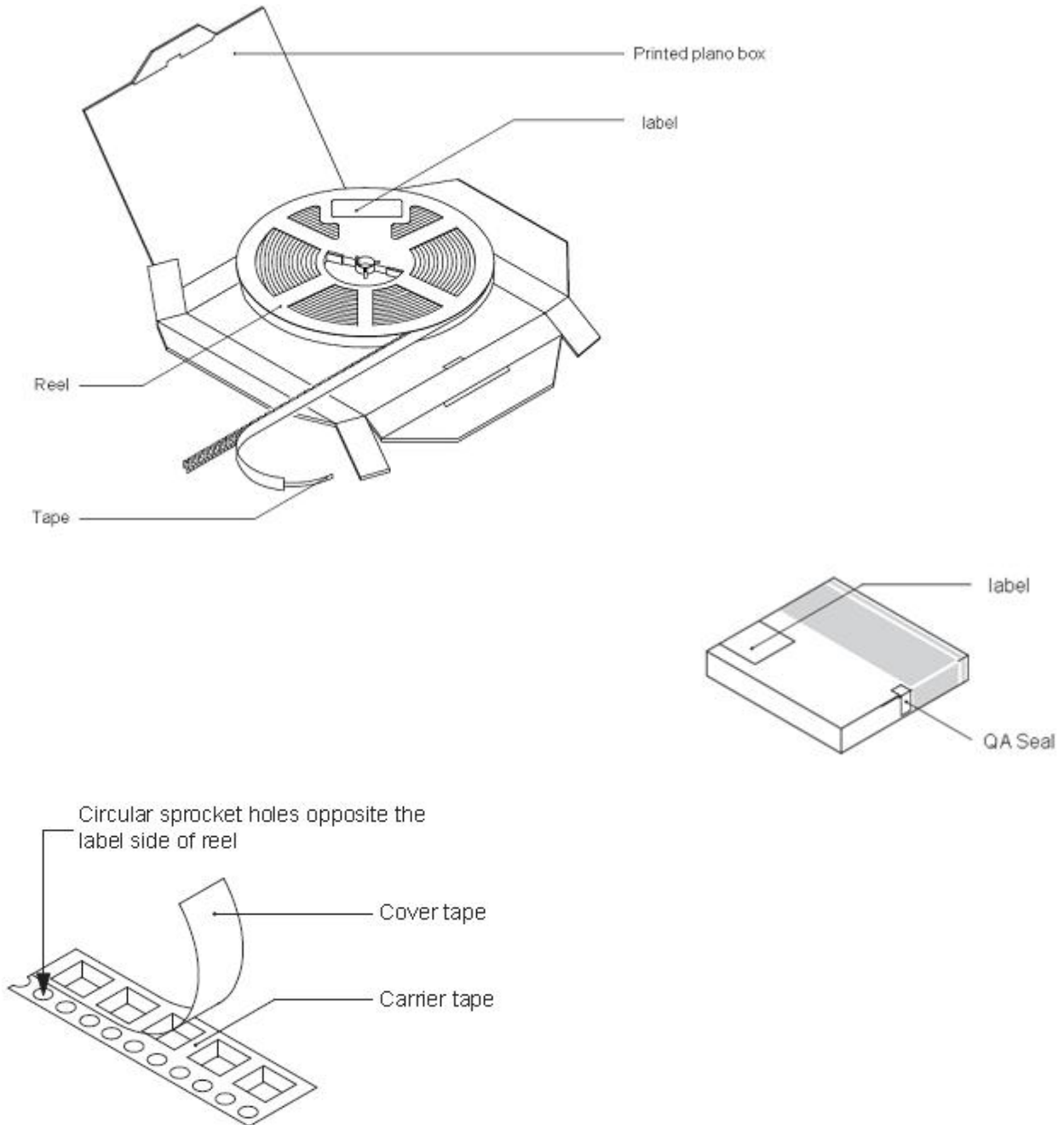
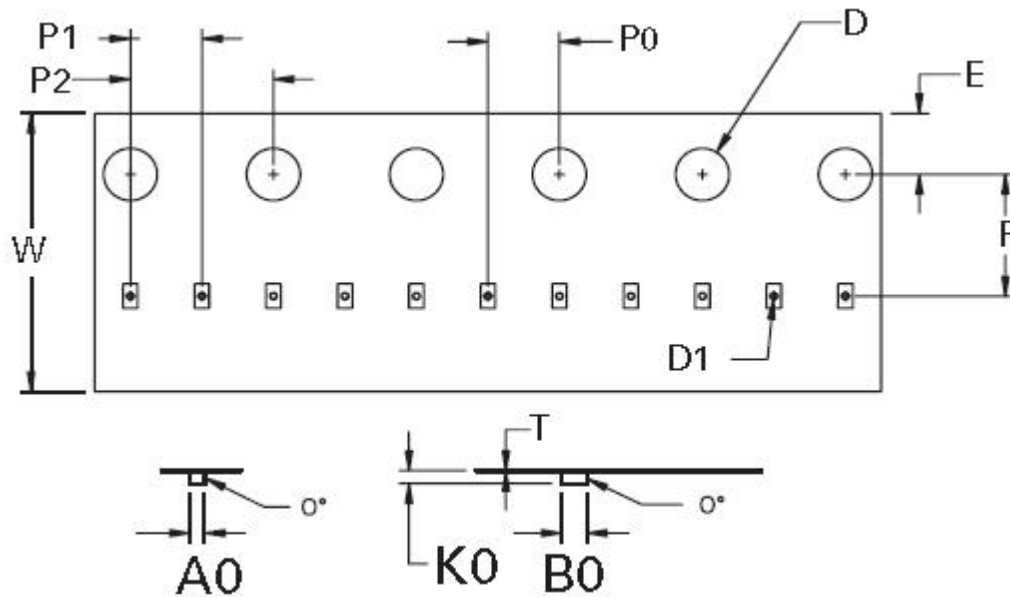

Fig.1- Reel pack for 0201 Flipship

Table 1. Packing information

Package version	Reel dimensions Φ *H(mm)	SPQ/PQ (pcs)	Reels per box	Inner box dimensions L*W*H (mm)
0201 Flipship	Φ 178*11.5	10000	1	200*200*25

3. Carrier tape dimensions



Symbol	Millimeters
A0	0.41 +/-0.03
B0	0.70 +/-0.03
D	\varnothing 1.50 + 0.10
D1	\varnothing 0.20 +/- 0.05
E	1.75 +/-0.10
F	3.50 +/-0.05
K0	0.38 +/-0.03
P0	2.00 +/-0.05
P1	2.00 +/-0.05
P2	4.00 +/-0.10
W	8.00 + 0.30 -0.10
T	0.23 +/-0.02

Fig 3. Carrier tape dimensions

5. Reel dimensions

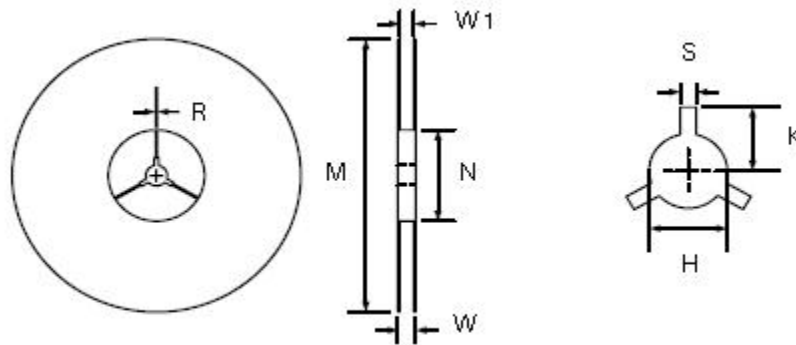

Symbol	Reel Dimensions (Size Ø 178)	
	Millimeters	
	Min	Max
M	177.0	179.0
N	59.0	61.0
W	11.0	12.0
W1	8.5	9.5
H	12.5	13.5
S	1.9	2.1
K	10.8	11.2
R	0.95	1.05

Fig 4. Reel dimensions